

6009 JITTERBUG SANDER

EXPLODED VIEW

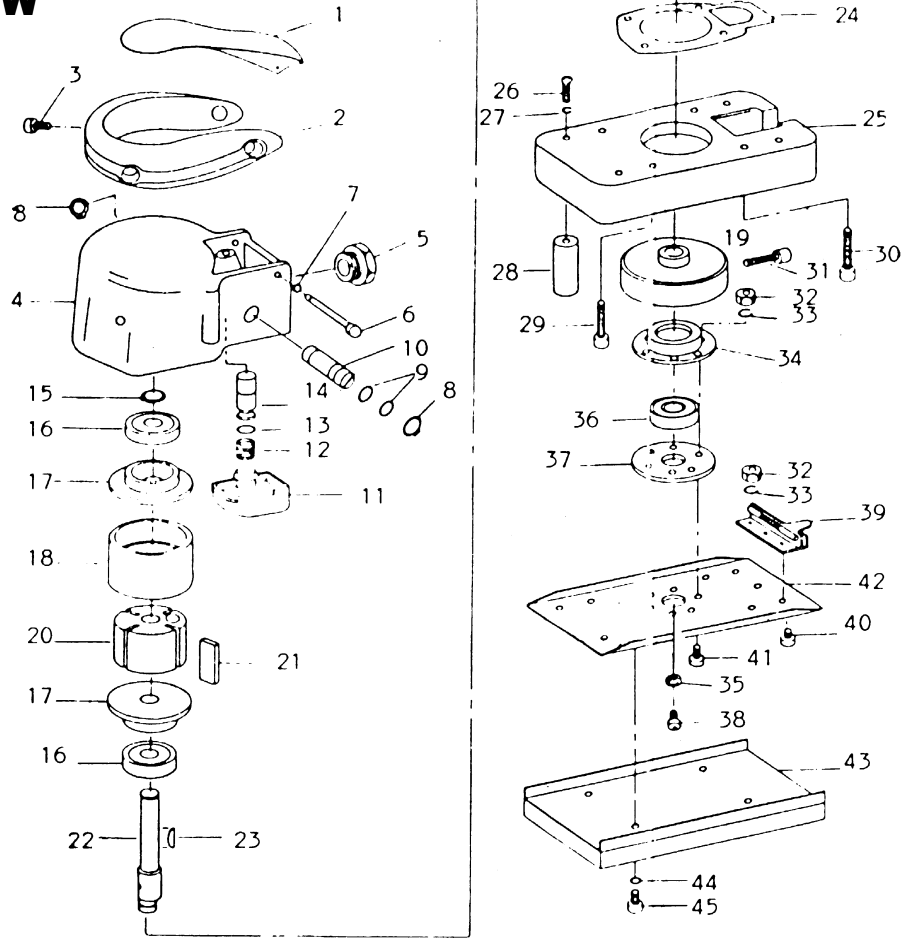

PARTS LIST – FOR REFERENCE ONLY

Index Number	Part Number	Description	Qty.	Index Number	Part Number	Description	Qty.	Index Number	Part Number	Description	Qty.
1	102101	Lever	1	16	102116	Ball Bearing	2	31	102131	Balancer Lock Screw	1
2	102102	Rubber Grip with Metal Strip	1	17	102117	End Plate	2	32	102132	Nut	1
3	102103	Grip Screw	4	18	102118	Cylinder with	1	33	102133	Lock Washer	6
4	102104	Body	1	19	102119	Balancer	1	34	102134	Bearing Housing	1
5	102105	Inlet screw	1	20	102120	Rotor	1	35	102135	Screw	1
6	102106	Lever Pin	1	21	102121	Rotor blade	4*	36	102136	Ball Bearing	1
7	102107	Lever Retainer	1	22	102122	Rotor shaft	1	37	102138	Washer	1
8	102108	Retaining Ring	2*	23	102123	Key	1*	38	102138	Washer	1
9	102109	O-Ring	2*	24	102124	Gasket	1*	39	102139	Paper clamp	1
10	102110	Speed Regulator	1	25	102125	Base	1	40	102140	Clamp Screw with Nuts	6
11	102111	Muffler	1	26	102126	Mount Screw	8	41	102141	Bearing Hang Screw	6
12	102112	Spring	1*	27	102127	Spring Washer	8	42	102142	Shoe Plate	1
13	102113	O-Ring	1*	28	102128	Rubber Post	4	43	102143	Sanding Pad	1
14	102114	Plunger	1	29	102129	Cap Screw	2	44	102144	Lock Washer	4
15	102115	Retaining Ring	1*	30	102130	Cap Screw	2	45	102145	Mount Screw	4

TECHNICAL DATA

	Max Air Pressure	Recommended Air Hose Size	RPM Free Speed	Max Air Flow CFM	Weight (lbs.)
6009	90 psi	3/8"	8,000	15	4.3

EAGLE

10000 SE Pine Street
Portland, OR 97216
503-254-6600
FAX 503-255-2615

When ordering spare parts, please specify tool type, part number and description.

FOOTNOTES

* Parts Available in Repair Kit 6009RK*

REVISED 7/99